

# HK827

## VOICE RECORD/PLAYBACK IC

20-30 SEC. TIME CAPACITY

### Features

- \* Single-chip , high-quality voice recording & playback solution
  - No external ICs required
  - Minimum external components
- \* Non-volatile Flash memory technology
  - No battery backup required
  - 100,000 times record cycles ( typical )
  - 100-years message retention ( typical )
- \* Single message of 20 to 30 seconds , with external resistor selection
- \* User-friendly , easy-to-use operation
  - Programming & development systems not required
  - Level-activated recording & edge-activated playback switches
- \* Low power consumption
  - Operating current : 25 mA ( typical , no load )
  - Standby current : 1  $\mu$ A ( typical , no load )
- \* Automatic power-down feature for longer battery life
- \* Chip Enable pin for simple message expansion
- \* Single 5V for power supply

### General Description

The HK827 device offers true single-chip solid-state storage capability and requires no software or micro-controller support . It provides high-quality recording and playback with a single 20-to 30-second message . It is ideal for portable voice recorders , toys, and many other consumer and industrial applications .

HONSITAK ELECTRONICS proprietary analog / multi-level volatile memory cells , each of which can typically store more than 256 voltage levels . The HK827 device stores and reproduces voice signals in their natural forms , eliminating the distortion that is often introduced by encoding and compression. The device combines a small size with low power consumption , non-volatility , and ease-of-use for a cost-effective solution to voice recording and playback.

### PinOut Diagram

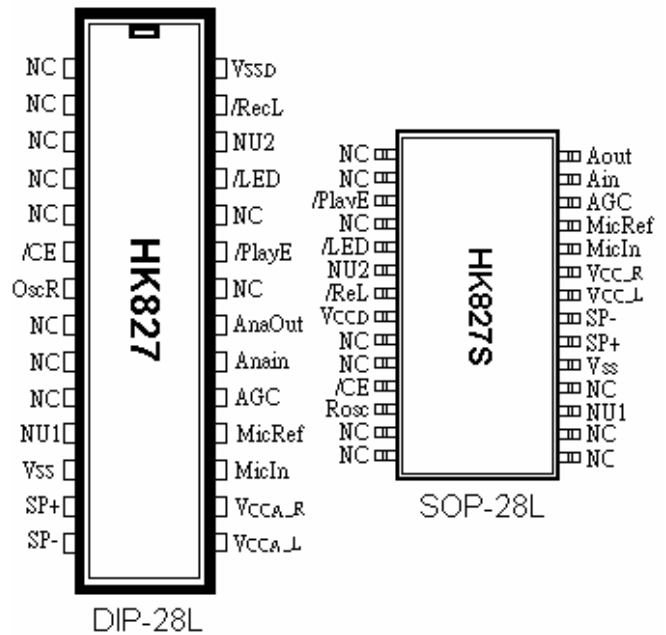

# HK827

## VOICE RECORD/PLAYBACK IC

20-30 SEC. TIME CAPACITY

### Block Diagram

Figure 2 shows the function block diagram

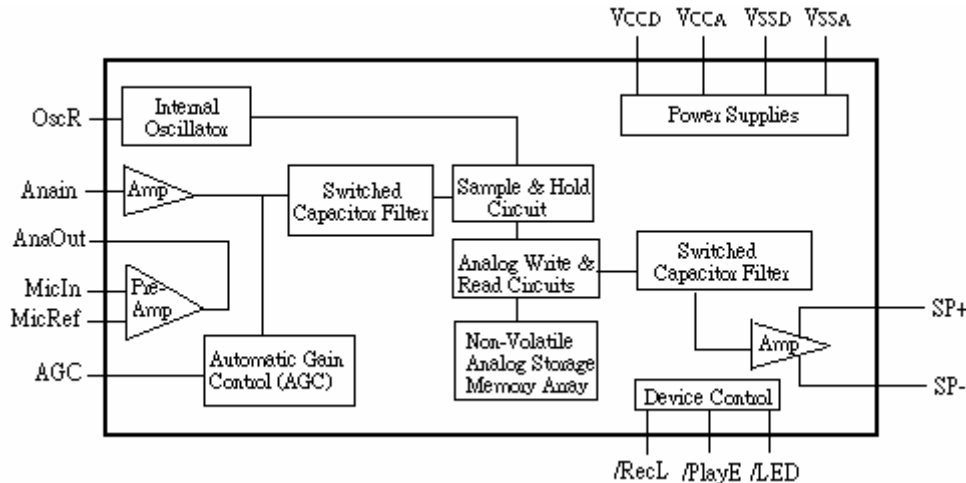

### Function Description

Figure 3 shows the diagram for a single, 20-second message recording and playback application using the HK827 device. When pins are connected as shown in this example, the operating modes are as follows:

#### Record Mode ( Level-Activated )

The /LED pin will go low during the actual recording process to provide a visual indication if an LED light is connected to this pin. A single voice message of up to 20 seconds can be recorded. The chip is in record mode as long as the /RecL pin stays low ( level-activated ). If the message lasts longer than 20 seconds, recording will terminate automatically after the last available memory cell is written. If the message is shorter than 20 seconds, the recording operation will stop when the /RecL pin goes high. The speaker driver is automatically tri-stated during the recording operation. Messages of up to 30 seconds can be recorded by using different OscR resistor values ( see Table 1 ).

#### Power Down Mode ( /CE="1" )

The chip is always in standby state. No recording or playback is allowed. Current consumption is typically less than 1  $\mu$ A.

#### Playback Mode ( Edge-Activated )

Playback always starts from the beginning of the message. The chip is in playback mode after the /PlayE pin pulses low ( edge-activated ). Playback will stop immediately when the /PlayE pin pulses low a second time. If the newly recorded message is shorter than the previously recorded message, the remaining portion of the previous message will be played after the new message is played back. The input pre-amplifier, AGC and main amplifier circuits are disabled during playback.

#### Standby Mode ( /CE="0" )

The chip will automatically return to the standby state after recording or playback operating is completed.

# HK827

## VOICE RECORD/PLAYBACK IC

20-30 SEC. TIME CAPACITY

Figure 3 shows the application circuit

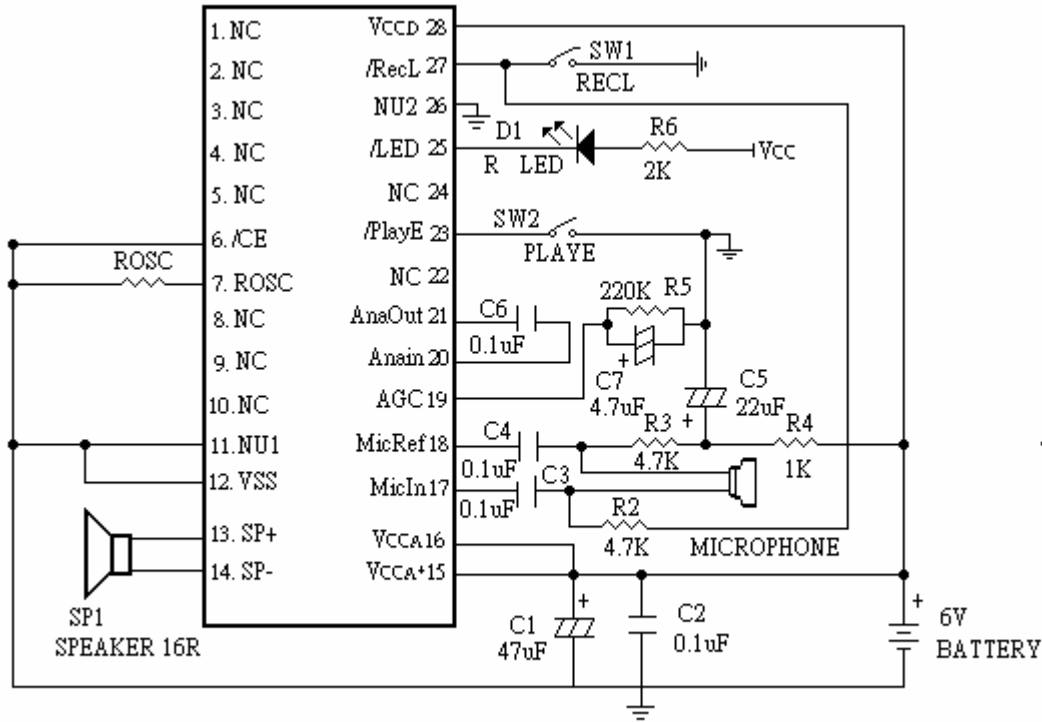

NC = No Connect (must be floating)  
 NU = Not Used (must be grounded)  
 Pins 23 and 27 have internal pull-up resistors.  
 The typical sampling frequency is 6.4 kHz with OscR = 52 K $\Omega$ .

Table 1. Typical Dependence of Sampling Frequency and Total Voice Duration on OscR Resistor Value  
 ( $V_{CCA} = V_{CCD} = 5V$ ;  $V_{SSA} = V_{SSD} = 0V$ ;  $T_A = 25^\circ C$ )

Pin 7 – OscR	Typical Sampling Frequency	Typical Total Voice Duration
52k $\Omega$	6.4 kHz	20 seconds
67k $\Omega$	5.3 kHz	24 seconds
89k $\Omega$	4.0 kHz	30 seconds

# HK827

## VOICE RECORD/PLAYBACK IC

20-30 SEC. TIME CAPACITY

### Electrical Characteristics

#### Absolute maximum Ratings

Item	Sym.	Condition	Min	Typ.	Max	Unit
Power supply voltage	V <sub>CC</sub>	T <sub>A</sub> = 25°C	3.8	6.0	7.0	V
Input voltage	V <sub>IN1</sub>	T <sub>A</sub> = 25°C	-0.3	-	V <sub>CC</sub> + 0.3	V
Input voltage	V <sub>IN2</sub>	I <sub>IN</sub>   < 20 mA	-1.0	-	V <sub>CC</sub> + 1.0	V
Storage temperature	T <sub>STG</sub>	-	-65	25	150	°C
Temperature under bias	T <sub>BS</sub>	-	-65	25	125	°C
Lead temperature	T <sub>LD</sub>	< 10 s	-0.3	25	300	°C

#### DC Characteristics\*

Item	Sym.	Condition	Min	Typ.	Max	Unit
Input high voltage	V <sub>IH</sub>	-	0.8*V <sub>CC</sub>	-	-	V
Input low voltage	V <sub>IL</sub>	-	-	-	0.8	V
Output high voltage	V <sub>OH</sub>	I <sub>OH</sub> = -1.6 mA	2.4	-	-	V
Output low voltage	V <sub>OL</sub>	I <sub>OL</sub> = 4.0 mA	-	-	0.45	V
Input leakage current	I <sub>IH</sub>	V <sub>IH</sub> = V <sub>CC</sub>	-	-	1.0	μA
Input leakage current	I <sub>IL</sub>	V <sub>IL</sub> = V <sub>CC</sub>	-1.0	-	-	μA
Output tristate Leakage current	I <sub>OZ</sub>	V <sub>OUT</sub> = V <sub>CC</sub> or V <sub>OUT</sub> = V <sub>SS</sub>	-1.0	-	1.0	μA
Operating current Consumption	I <sub>CC</sub>	Internal Clock, no load	-	25	-	mA
Standby current consumption	I <sub>CCS</sub>	No load	-	1.0	-	μA

#### Analog Characteristics\*

Item	Sym.	Condition	Min	Typ.	Max	Unit
MicIn input voltage	V <sub>MI</sub>	-	-	-	20	mVp-p
MicIn input resistance	R <sub>MI</sub>	-	-	10	-	KΩ
MicIn amp gain (1)	G <sub>MI1</sub>	AGC = 0 V	-	24	-	dB
MicIn amp gain (2)	G <sub>MI2</sub>	AGC = 2.5 V	-	-45	-15	dB
Analn input voltage	V <sub>ANI</sub>	-	-	-	50	mVp-p
Analn input resistance	R <sub>ANI</sub>	-	-	10	-	KΩ
Analn amp gain	G <sub>ANI</sub>	Analn to SP +/-	-	22	-	DB
AGC output resistance	R <sub>AGC</sub>	-	-	1	-	KΩ
Sp +/- output power	P <sub>sp</sub>	R <sub>SP</sub> +/- = 16 Ω	-	12.2	-	mW
Voltage amplitude across SP +/-	V <sub>sp</sub>	R <sub>SP</sub> +/- ≥ 16 Ω	-	1.25	-	Vp-p

Typical Values : V<sub>CCD</sub> = V<sub>CCA</sub> = 5V ; V<sub>SSD</sub> = V<sub>SSA</sub> = 0V ; T<sub>A</sub> = 25°C

# HK827

## VOICE RECORD/PLAYBACK IC

20-30 SEC. TIME CAPACITY

### Bonding Pad Diagram & Description Of Bonding Pad Coordinates

Figure 4 shows the die bonding pad

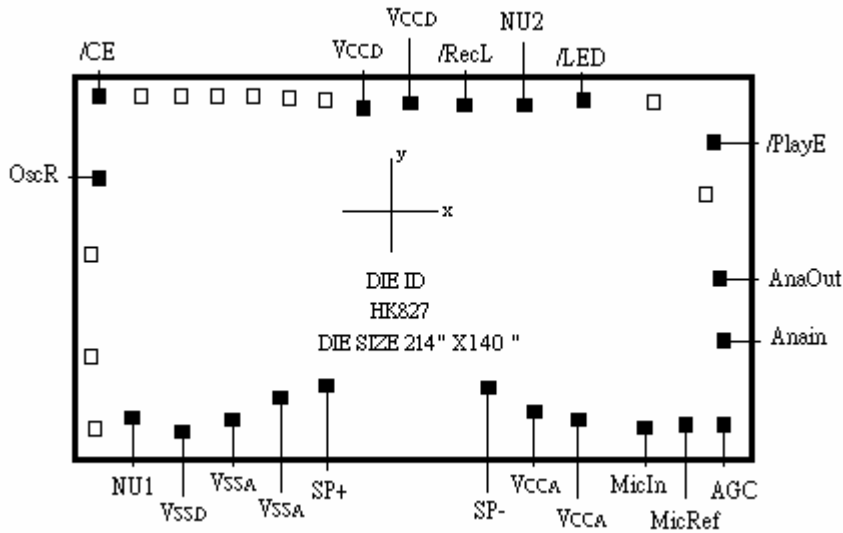

Substrate must be connected to Vssd & Vssa\_L & Vssa\_R

Pin	Pin Name	X Axis*	Y Axis*
/ICE	Chip enable	-2496.20	1565.80
OscR	Oscillator frequency-setting resistor	-2459.55	729.80
NU1	Connect to ground	-1808.45	-1496.10
VSSD	Digital ground supply	-1564.05	-1572.00
VSSA	Analog ground supply	-1384.05	-1548.70
VSSA	Analog ground supply	-1204.35	-1477.10
SP+	Non-inverting speaker output	-707.15	-1390.00
SP-	Inverting speaker output	479.15	-1389.90
VCCA	Analog power supply	976.45	-1492.00
VCCA	Analog power supply	1190.40	-1523.70
MicIn	Microphone input	1619.45	-1551.40
MicRef	Microphone reference input	2035.45	-1551.40
AGC	Automatic gain control	2487.45	-1551.40
Anain	Analog signal input	2487.45	-1049.90
AnaOut	Analog signal output	2487.45	-949.90
/PlayE	Edge-activated playback	2493.65	1371.10
/LED	LED output	1430.70	1565.80
NU2	Connect to ground	865.75	1565.80
/RecL	Level-activated record	258.15	1565.80
VCCD	Digital power supply	-229.40	1579.05
VCCD	Digital power supply	-510.80	1541.60

# HK827

## VOICE RECORD/PLAYBACK IC

20-30 SEC. TIME CAPACITY

### Package Outlines

The HK827 device is available in the DIP and SOP package forms , Packages conform to JEDEC and EIAJ standards.

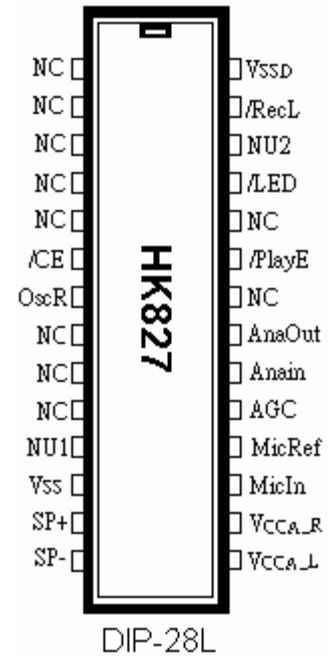
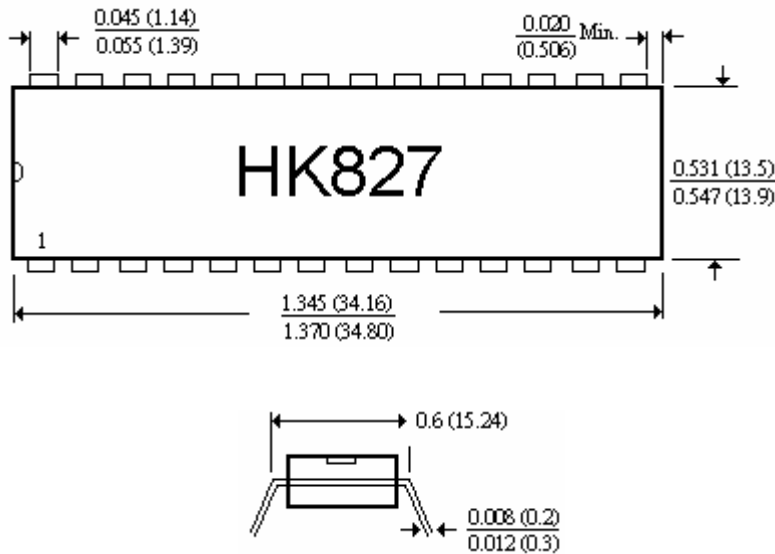

( A ) 28-Pin Plastic Dual In-Line Package ( DIP-28L, P-600 )

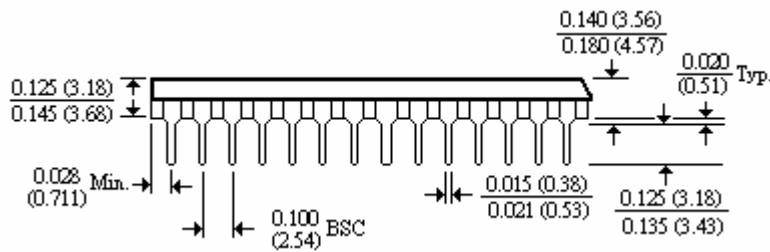

# HK827

VOICE RECORD/PLAYBACK IC

20-30 SEC. TIME CAPACITY

( B ) 28-Pin Plastic Small-Outline Integrated Circuit ( SOP-28L)

